

Datasheet

Subject to technical alteration
Issue date: 26.02.2018 • A001



Application

Water leak detection sensor with LED signal and relay output. Designed for alarm, control and monitoring applications.

Types Available

Water leak detection sensor

LS02+

Security Advice – Caution



The installation and assembly of electrical equipment should only be performed by authorized personnel.

The product should only be used for the intended application. Unauthorised modifications are prohibited! The product must not be used in relation with any equipment that in case of a failure may threaten, directly or indirectly, human health or life or result in danger to human beings, animals or assets. Ensure all power is disconnected before installing. Do not connect to live/operating equipment.

Please comply with

- Local laws, health & safety regulations, technical standards and regulations
- Condition of the device at the time of installation, to ensure safe installation
- This data sheet and installation manual

Notes on Disposal



As a component of a large-scale fixed installation, Thermokon products are intended to be used permanently as part of a building or a structure at a pre-defined and dedicated location, hence the Waste Electrical and Electronic Act (WEEE) is not applicable. However, most of the products may contain valuable materials that should be recycled and not disposed of as domestic waste. Please note the relevant regulations for local disposal.

General remarks concerning sensors

Especially with regard to passive sensors in 2-wire conductor versions, the wire resistance of the supply wire has to be considered. If necessary the wire resistance has to be compensated by the follow-up electronics. Due to self-heating, the wire current affects the measurement accuracy, so it should not exceed 1 mA.

When using lengthy connection wires (depending on the cross section used) the measuring result might be falsified due to a voltage drop at the common GND-wire (caused by the voltage current and the line resistance). In this case, 2 GND-wires must be wired to the sensor - one for supply voltage and one for the measuring current.

Sensing devices with a transducer should always be operated in the middle of the measuring range to avoid deviations at the measuring end points. The ambient temperature of the transducer electronics should be kept constant. The transducers must be operated at a constant supply voltage ($\pm 0,2$ V). When switching the supply voltage on/off, onsite power surges must be avoided.

Technical Data

Measuring values	humidity	
Output switch contact	changeover contact, 24 V: max. 24 V / 1,0 A (resistive, floating)	
Power supply	15..24 V = ($\pm 10\%$) or 24 V ~ ($\pm 10\%$) SELV	
Power consumption	typ. 0,6 W (24 V =) 1,5 VA (24 V ~)	
Sensor	4 detector electrodes stainless steel V2A	
Display	PWR - LED green power supply OK,	DETECT - LED red alarm, leakage detected
Enclosure	enclosure USE-S, PC, pure white	
Protection	IP65 according to EN 60529	
Cable entry	M16 for wire max. $\varnothing=0.8$ mm, removable	
Connection electrical	removable plug-in terminal, max. 2,5 mm ²	
Ambient condition	0..+60 °C, max. 85% rH short term condensation	
Mounting	adjustment in height is possible using adjustable contacts	

Mounting Advices

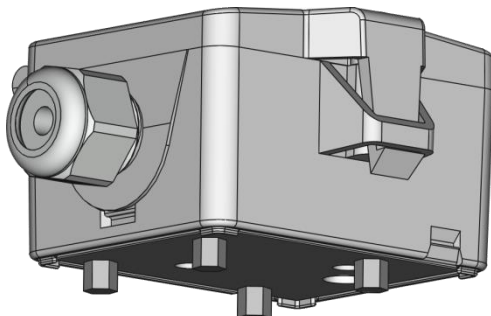

The leakage sensor lies with its own weight on the four contact feet. The detector electrodes are electrically insulated at the lower end, whereby a surface condensation is not detected. The height of the insulation can be variably adjusted, which makes it easy to adapt to local conditions.

Depending on the type and concentration, aggressive and solvent-containing fluids can damage the sensor and lead to incorrect measurements. A contamination of the sensor electrodes also leads to incorrect measurements.

Connection Plan

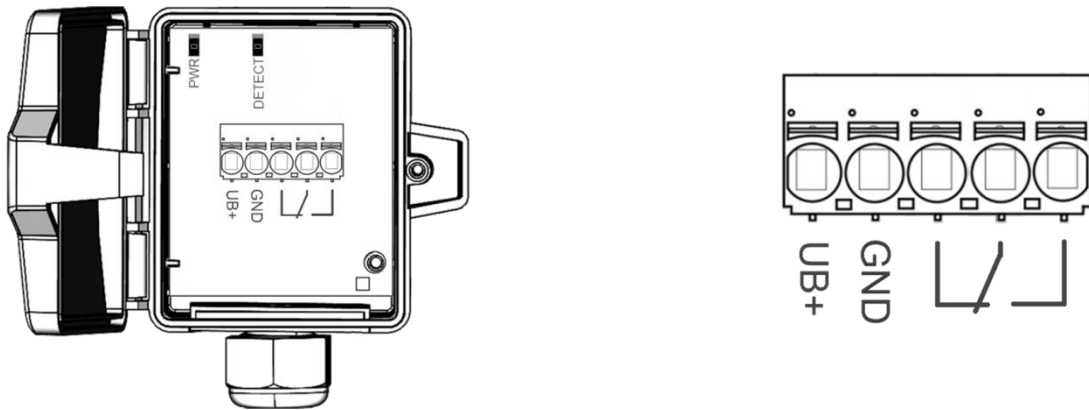

The representation of the relay contact indicates the operating state "Devices connected to voltage supply and no leakage is detected". The relay is energized in this operating state. When condensation or when switching off the operating voltage, it falls off.

Dimensions (mm)

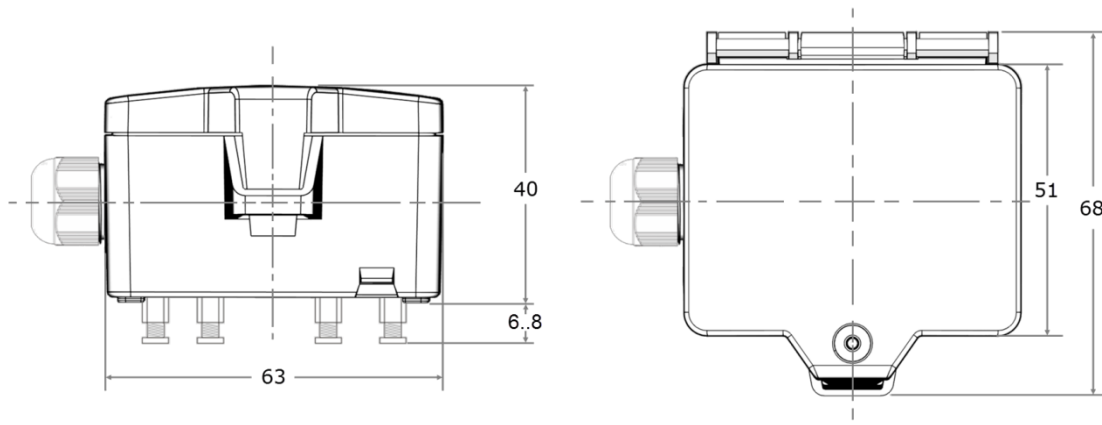

Accessories (optional)

M16 Sealing inserts cable entry (packaging unit 10 pcs.)

for wire with Ø	3 mm	5 mm	7 mm	8 mm
Item No.	641036	641012	639248	641340